

RIGHT SIDE VIEW

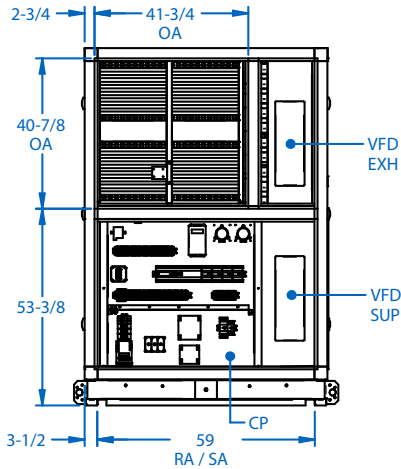

REAR VIEW

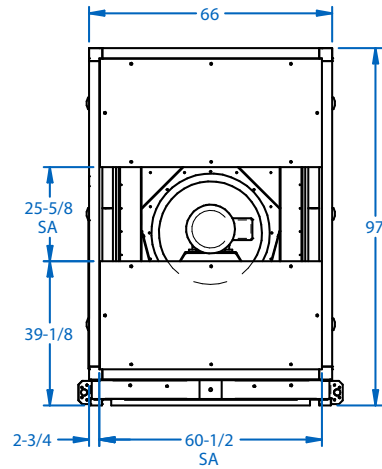

FRONT VIEW

UNIT DESIGN CONDITIONS AND CAPACITIES

Nominal Air Flow (SA) CFM @ 1.5"ESP	15,000
Cabinet SA Range, CFM	8,000-15,000
Max Outdoor Airflow (OA) CFM	9,000
Typ.* Moisture Removal, lb/hr @ Max OA	162
Unit Weight, lbs	6,400
Typ.* Max Aux Hot Water Cap., MBH	654
Heat Pipe (HP), Max Size	C
HP Min Airflow, CFM	2,080
HP Max Airflow, CFM	5,200
HP Typ.* Capacity, MBH	225

*Typical (Typ.) capacities as determined at 84°F, 60%RH space, 2°F OAT, 60°F OA dpt with largest standard components

VOLTAGE	208-230/3PH	460/3PH	575/3PH
MCA	92	45	32
MOP	115	57	36

@Nom SA, 60% OA

STANDARD FEATURES:

- SuperVisaire® Control System
- Remote Wireless Factory Monitoring
- Direct-drive Plenum Fans
- Vertical Heat Pipe
- 2" Double Walled Cabinet
- Active Airflow Control
- Exhaust Fan Purge/Economizer

OPTIONAL FEATURES SHOWN

- Hot Water Coil
- Indoor Configuration

AVAILABLE OPTIONS

- BACnet IP or MS/TP Interface
- Outdoor Cabinet Design
- Gas or Hot Water Auxiliary Heating
- Chilled Water Coil Auxiliary Cooling
- Higher or Lower Airflows or Static Pressures
- Unit Mounted Disconnect